

X200 SERIES (CMOS)

STANDARD SPECIFICATIONS

(Similar to M55310/18)

FREQUENCY RANGE	1.5 Hz to 12 MHz
FREQUENCY ACCURACY @ +25 °C	± 0.0015% (± 15 PPM)
FREQUENCY STABILITY Vs. TEMPERATURE	See Options Below
OPERATING TEMPERATURE RANGE	See Options Below
INPUT VOLTAGE (See note below)	+ 5 VDC to + 15 VDC ± 10%
INPUT CURRENT	5 mA Max. @ + 5 VDC 25 mA Max. @ + 15 VDC
OUTPUT	CMOS
LOAD	200 KΩ in parallel with 50 pf
SYMMETRY	60/40% @ 50% Output Level
RISE & FALL TIMES (10% to 90% Output Level)	150 nS Max. @ + 5 VDC 50 nS Max. @ + 15 VDC
START-UP TIME	
< 10 MHz	20 mS Max.
≥ 10 MHz	15 mS Max.
FREQUENCY STABILITY Vs. VOLTAGE	± 0.0005% (± 5 PPM) Max. (for 10% change in Voltage)
AGING @ +25 °C	± 0.0005% (± 5 PPM) / year Max.
PACKAGE, SEAL & LEAD FINISH	Conforms with the Requirements of MIL-PRF-55310

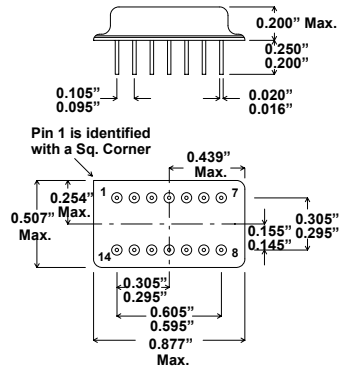

Pin Connections

14	B+
7	GND
8	OUTPUT
All Others	N/C

Note: Input Voltage must be specified for 200 Series CMOS parts, minimum input voltage required depends upon output frequency and operating temperature range. Consult factory for your specific application.

Contact Xsis Engineering for special requirements such as, **Output Symmetry, Start-up Time, Frequency Accuracy, Complementary Outputs, Multiple Outputs, etc.**

ORDERING INFORMATION (Select from options below) :

X
2

-

-
FREQUENCY

Frequency Stability ● Add Suffix "883B" for Mil-Screened Option

1 = ± 0.1%	1 = 0 °C to + 70 °C
2 = ± 0.05%	2 = - 30 °C to + 85 °C
3 = ± 0.01%	3 = - 55 °C to +125 °C
4 = ± 0.005%	
5 = ± 0.002% *	

* Option 5 not available for - 55 °C to +125 °C

EXAMPLE: X243 - 883B - 4.000 MHz = 14 Pin Package with "X" Pinout, CMOS, ± 0.005% over -55 °C to +125 °C, Mil-Screened , and 20.000 MHz